

Design Strategies for High-Temperature, High-Pressure Optical Cells

Steven F. Rice, Richard R. Steeper, Costanzo A. LaJeunesse, Russell G. Hanush, and Jason D. Aiken

Combustion Research Facility
Sandia National Laboratories, MS-9052
P.O. Box 969

Livermore, CA 94551-0969

Fax: (510) 294-1004 Email: sfrice@sandia.gov

17 - 1997

The past several years have seen an increasing effort to apply optical and spectroscopic techniques to a variety of research projects in supercritical fluids. However, many experimental apparatus are plagued with sporadic leaks or cracked windows. Over the past several years, we have developed two optical cell designs: one for flow reactors, and the other for larger batch reactors. The flow system design uses spring washers to balance the unequal thermal expansions of the reactor and the window materials. This design has been used for 0.2-cm windows with $f/3$ light-collection mounted in a 0.48-cm-ID flow reactor. A typical design calculation is presented showing the relationship between system pressure, operating temperature, and torque applied to the window-retaining nut. The second design employs an older strategy more appropriate for larger windows. This design uses two seals: one for the window that benefits from system pressure, and a second one that relies on knife-edge, metal-to-metal contact. This design is used in a batch reactor in which we have also installed a stirring mechanism.

Introduction

There are many new research methods in the thermophysical sciences that require optical access to high-temperature and high-pressure environments. Examples include materials synthesis research, pressurized water reactor studies, and supercritical fluids research. However, the successful application of optical and spectroscopic methods in high temperature fluids at elevated pressure requires reliable cell design that can typically withstand repeated thermal and pressure cycling.

This paper addresses the design of optical cells suitable for supercritical water (SCW) research, where pressures and temperatures can exceed 50 MPa and 500 °C. Such cells are prone to sporadic leaks and cracked windows due to unbalanced thermal expansion of the windows and the walls. Over the past several years we have developed design improvements to two basic optical cell strategies, yielding two reliable reactors for our SCW research. One reactor is a flow reactor which houses a *flow optical cell*. The other is a larger batch reactor called the *stirred optical cell*.

The flow optical cell design depends on a spring washer to accommodate the thermal expansion mismatch between the cell and the window material. The design is patterned after that of Abdullah and Sherman [1] for Raman spectroscopy at high pressure in cryogenic systems. A similar cell has also been reported recently by Bowers et al. [2]. Our design has the advantage of a simplified gold gasket. Design calculations are provided to permit application of the design to other cell configurations. The design of our second reactor, the stirred optical cell, is based on the design of Franck and

coworkers [3]. The design relies on two seals: the window seal which takes advantage of system pressure to press the window against its gasket, and the main seal that relies on an easily maintained, knife-edge contact between two metal parts.

Flow optical cell

Our flow optical cell is designed to fit into a 1.42 cm (9/16" OD, 0.477 cm (3/16") ID high-pressure flow reactor. The optical cell can be inserted at any point in the 3-m reactor, allowing optical access to the flow over a wide range of residence times. That system is described in detail elsewhere [4,5].

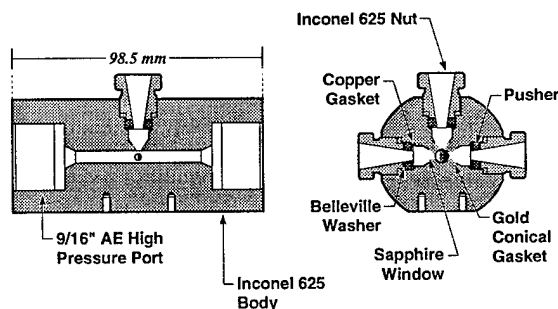

Figure 1. Cross-section of the flow optical cell.

The cell, illustrated in Fig. 1, provides direct optical access to the reacting flow and is constructed of Inconel 625. Three ports, 0.2 cm in diameter and located at 90° intervals, are fitted with Hemex CSI Ultra-VUV grade sapphire windows procured from Crystal Systems, Inc. The cell is heated by two Watlow, 175-W, resistive band heaters. To maintain alignment of the cell with respect to the other optical

components, it is immobilized on the table, and the thermal expansion of the rest of the reactor occurs in both directions away from the optical cell.

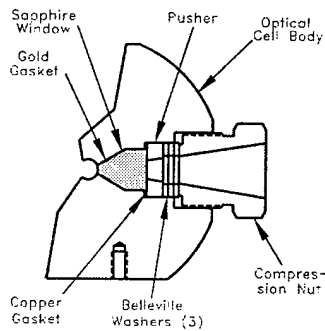

Figure 2. Detail of the flow optical cell window seal.

The design of the window seal in the cell, shown in detail in Fig. 2, relies on a balance between the force exerted on the window by the pressure within the cell and the force applied to the window by the compression nut. The actual seal is achieved with a gold gasket placed between the window and the cell body. This gasket is originally a flat washer (0.033 cm ID, 0.063 cm OD, and 0.025 cm thick), that is deformed into a cone when the window is pressed into the assembly. An oxygen-free copper gasket is placed between the slip plate ("pusher") and the window to assure even distribution of force across the window.

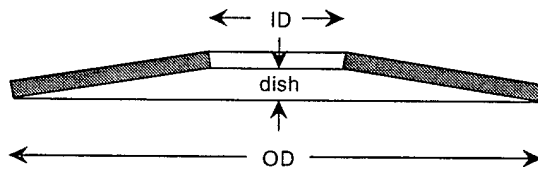

Figure 3. Cross-section of the Belleville washer.

Three Belleville washers, Fig. 3, serve as a spring to maintain sufficient force on the windows as the cell dimensions change relative to the window during thermal expansion. The coefficient of thermal expansion, μ , is $13 \mu\text{m}/\text{m}\cdot^\circ\text{C}$ for the cell (Inconel 625) and $7.7 \mu\text{m}/\text{m}\cdot^\circ\text{C}$ for the sapphire window, yielding $\Delta\mu = 5.3 \times 10^{-6} \text{ m}/\text{m}\cdot^\circ\text{C}$. The length, l , of the window is 1.11 cm. For our typical $\Delta T = 500^\circ\text{C}$, the distance between the compression nut and the window changes by

$$\Delta l = (\Delta\mu)(\Delta T)l = 0.003 \text{ cm.} \quad (1)$$

Thus, to maintain compression on the gold seal, the Belleville washer must expand 0.003 cm while still balancing the force on the window from the high-pressure fluid inside the cell.

Belleville washers can be obtained in a wide variety of diameters, force constants, and dish dimensions. The force constant, k_w , of the washers used in our design is approximately $1.4 \times 10^7 \text{ N/m}$, with a dish dimension of 0.013 cm. Washers designed for high loads and small deflections deflect linearly with load. At full compression, the washer displacement, d , equals the dish dimension resulting in a force on the washer of $F_w(\text{max}) = 1.8 \times 10^3 \text{ N}$ from

$$F_w = k_w d. \quad (2)$$

When the cell is heated, the washer displacement decreases 0.003 cm according to Eqn. 1 such that $d = 0.010 \text{ cm}$ and $F_w = 1400 \text{ N}$. The force on the window from the fluid is simply

$$F_f = PA, \quad (3)$$

where P is the pressure in the cell and A is the effective wetted area of the window. If the wetted perimeter is conservatively estimated to be located at the OD of the gold gasket, then $A = 0.32 \text{ cm}^2$ and $F_f = 1600 \text{ N}$ at an operating pressure of 50 MPa. The opposing force from a single washer of 1400 N is inadequate. However, by placing three washers in parallel, the force constant of the system can be increased threefold to $4.2 \times 10^7 \text{ N/m}$. With this design, $d(\text{max})$ is still 0.013 cm, $F_w(\text{max})$ becomes 5320 N, and F_w at temperature is 4200 N, providing a large factor of safety. Because the washers are made of Inconel 718, we expect no significant change in the force constant for operating temperatures below 600°C .

In practice, F_w is not measured. The washers are compressed by the nut that is driven by a torque wrench such that

$$F_w = T/KD \quad (4)$$

where T is the torque, K is a thread constant (taken to be 0.2 for unlubricated threads), and D is the thread diameter of 1.75 cm (11/16 in). Using Eqn. 4, the torque on the wrench when the washers are fully compressed is calculated to be 19 N-m, which is very near the observed 20 N-m where the "feel" on the wrench is that of significant stiffening or "bottoming out." At this point the three washers are flat and adequate force is applied to the gold gasket to deform it into a good seal. If the nut is turned beyond this point, torque increases rapidly with very little travel, and the force will crack the sapphire.

After approximately 20 thermal cycles, the windows often begin to leak. Testing after disassembly shows that the ambient-temperature

torque on the windows has dropped below 12 N-m, caused by creep of the gold gasket that allows the window to sink deeper in its seat. As the window moves, washer deflection and F_w decrease. A leak occurs when creep allows sufficient travel that the washers can no longer balance fluid pressure. At our typical operating conditions of 25 MPa, the fluid exerts a force $F_f = 800$ N from Eqn. 3. Setting $F_w = 800$ N to just balance F_f implies a washer deflection $d = 0.0019$ cm (Eqn. 2 with $k_w = 4.2 \times 10^7$). To get to this state, the washer deflection has to decrease 0.008 cm ($d(\text{initial}) = 0.010$ cm and $d(\text{final}) = 0.0019$ cm), which could occur if the gold gasket thickness decreases from 0.025 cm to 0.017 cm. At this state, torque on the nut is calculated to be 2.8 N-m at operating temperature, or 7.4 N-m cold. In practice, we observe torques of 5–10 N-m on leaking seals, with the gold gaskets measuring 0.010–0.015 cm in thickness.

Stirred Optical Cell

Our stirred optical cell (Fig. 4) is a batch-type reactor capable of similar operating conditions as the flow cell, but providing a larger internal volume and larger windows [6]. As its name implies, it is equipped with a mechanical stirring device.

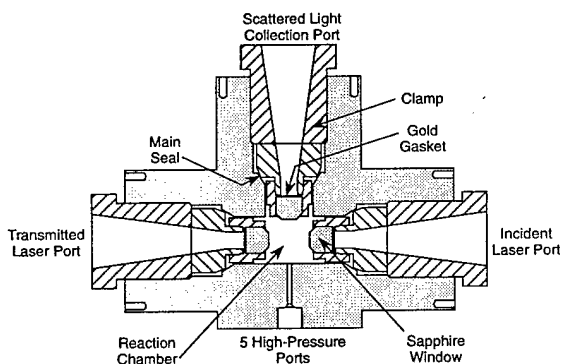

Figure 4. Cross-section schematic of the batch reactor without the stirrer.

This reactor uses fluid pressure to help seal its sapphire windows. As seen in Fig. 5, a window cap holds the window against a gold gasket. Torquing the cap to 100 N-m deforms the 0.025-cm gasket sufficiently to provide an initial seal, and subsequent pressurization of the reactor improves the window seal. The main seal holds the window assembly and is itself sealed by means of slightly mismatched tapers: the main seal is machined to $58^\circ \pm 1^\circ$, and the reactor body is machined to $61^\circ \pm 1^\circ$. The line of contact between these two components is a knife-edge, generating high contact pressures as the gland nut is torqued (typically to 650 N-m). The reactor

body and main seal are both made of Inconel 718, but the vessel is hardened so that most deformation occurs on the main seal. Thus reconditioning is easily accomplished by retouching the main seal taper on a lathe. Differential thermal expansion is not a problem in this design since the contacting parts are made of the same material,

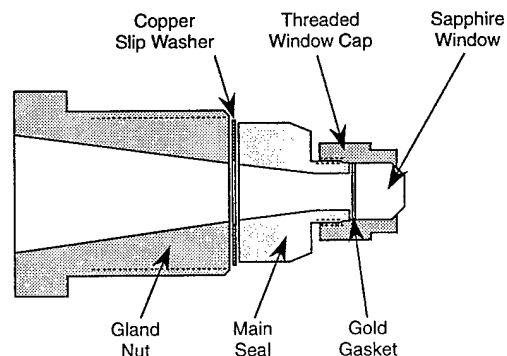

Figure 5. Cross-section of the window seal and main seal.

The batch reactor is typically used for kinetics experiments [7] in which a reactant is rapidly injected into a high-density mixture so that its destruction rate can be measured by Raman spectroscopy. Following injection, we have found that unaided mixing occurs on a time scale of several minutes. This is adequate for kinetics experiments with time scales of tens of minutes to hours. But for faster reactions, we require mechanical mixing.

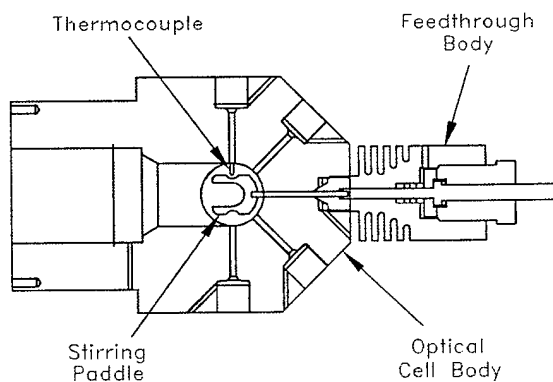

Figure 6. Cross-section of the stirred optical cell showing the stirring mechanism.

Figure 6 is a schematic of the stirring system we fabricated. Similar to other mechanically-actuated high-pressure feedthrough [8], it is based on a packed valve stem with dimensions similar to Autoclave Engineers, Inc. high-pressure valves. The shaft is driven by a variable speed electric motor and is operated at approximately 200 rpm for 5 seconds during injection in a typical experiment—sufficient

time to thoroughly mix the reactor contents. The horseshoe-shaped paddle is designed so that when positioned vertically, it does not interfere with the input laser beam or the scattered light collection.

Conclusions

The design principles for two high-pressure, high-temperature optical cells suitable for research in supercritical fluids are presented and illustrated by example. The smaller design is used in a SCW flow reactor. Its single seal depends on spring washers to balance system pressure. The design for larger windows is used in a SCW batch reactor. System pressure maintains the window seal, while a second, main seal relies on metal-to-metal, knife-edge contact. By adding a mechanical stirrer, we can use this reactor to optically measure kinetics rates for reactions with time scales as short as tens of seconds.

Acknowledgments

This work was supported by the DoD/DOE/EPA Strategic Environmental Research and Development Program (SERDP).

References

1. Abdullah, A. H.; Sherman, W. F. *Journal of Physics E: Scientific Instruments* **1980**, *13*, 1155-1159.
2. Bowers, Jr., W. J.; Bean, V. E.; Hurst, W. S. *Rev. Sci. Instrum.* **1995**, *66*(2), 1128-1130.
3. Schilling, W.; Franck, E. U. Ber. *Bunsenges. Phys. Chem.* **1988**, *92*, 631-636.
4. Rice, S. F.; Hunter, T. B.; Rydén, Å. C.; Hanush, R. G. *Ind. Eng. Chem. Res.* **1996**, *35*(7), 2161-2171.
5. Hanush, R. G.; Rice, S. F.; Hunter, T. B.; Aiken, J. D. "Operation and Performance of the Supercritical Fluids Reactor" Sandia National Laboratories Report No. SAND96-8203, **1995**.
6. Steeper, R. R.; Rice, S. F.; Brown, M. S.; Johnston, S. C. "Methane and Methanol Diffusion Flames in Supercritical Water" Sandia National Laboratories Report No. SAND92-8474, **1992**.
7. Steeper, R. R.; Rice, S. F.; Kennedy, I. M.; Aiken, J. D. *J. Phys. Chem.* **1996**, *100*, 184-189.
8. Costantino, M. *Rev. Sci. Instrum.* **1991**, *62*(6), 1668-1669.